

Air-Weigh[®]

Self-Weighing Truck and Trailer Scales[™]



QuickLoad On-Board Scale Steer Axle Deflection Sensor Kit Installation Guide

For Use on Vehicles with Steel Spring Steer Axles

Please Read Before Installing

901-0145-000 R0

TABLE OF CONTENTS

I. SCALE OVERVIEW	3
1. Steer Axle Sensor Installation Overview	3
II. INSTALLATION COMPONENTS	7
III. TOOLS REQUIRED (CUSTOMER SUPPLIED)	9
2. Required Tools	9
3. Optional	9
IV. INSTALLING THE STEER AXLE SENSOR	10
1. Installing the Steer Axle Deflection Sensors	10
A. Preparing the Steer Axle and Sensor Brackets ..	10
B. Assembling the Glue Kit	13
C. Applying the Adhesive	14
D. Mounting the Brackets on the Steer Axle	15
2. Deflection Sensor Installation	17
A. Inserting the Sensor into the Bracket	17
3. Setting the Sensor A/D Values	19
A. Assembling the Connectors	19
B. Tightening the Nuts on the Sensor Assembly ...	20
C. A/D Reading is BELOW 750	21
D. A/D Reading is ABOVE 1250	21
E. Final Sensor Torque	21
F. Attaching Connector Assembly to Bracket Tab	22
G. Driver's Side Sensor Orientation	22
H. Passenger Side Sensor Orientation	23
I. Installing the Cover	24
LIMITED WARRANTY	28
PROCEDURE FOR WARRANTY CLAIMS	29
APPENDIX A	30

I. SCALE OVERVIEW

The Air-Weigh Steer Axle Deflection Sensor is a major component of several Air-Weigh Tractor/Truck Scale kits. Properly installed, it allows the user to determine the weight on a spring-ride steer axle.

This **Installation Guide** (P/N 901-0145-000) gives instructions for steer deflection sensor installations for vehicles having steel spring axles in combination with air drive suspensions.

Follow the installing procedures in this guide exactly for the most accurate weighing.

The **User Guide** (P/N: 901-0124-000), included with the scale kit, provides the complete scale calibration and operation procedures.

You must have the QuickLoad Scale installed and powered to be able to check A/D readings using the DIAGNOSTICS menu in the display. See the **Display Kit Installation Guide** (P/N 901-0123-000) for scale installation instructions. Alternately, you can also use the optional Deflection Sensor Test Device to get measurements directly at the sensor.

1. Steer Axle Sensor Installation Overview

The following overview steps are to be applied to the Steer Axle Sensor Installation.

- Mark the center of the axle and prepare it for gluing.
- Apply glue to the bottom of the bracket assembly.
- Mount bracket assembly on the axle and secure with band clamps.
- Tighten the band clamps and allow the glue to cure.
- Apply epoxy paint over glue and axle seams and allow drying.
- Mount the deflection sensor and connector mounting tab on the brackets.

- Route the extension cable through the firewall and connect it to the QuickLoad scale.
- Check for sensor readings in range.
- Connect the extension cable to the sensor electrical connector on the mounting tab.
- Mount the cover over the sensor and brackets and secure with band clamps.

GLUE INSTALLATION OVERVIEW DRAWINGS

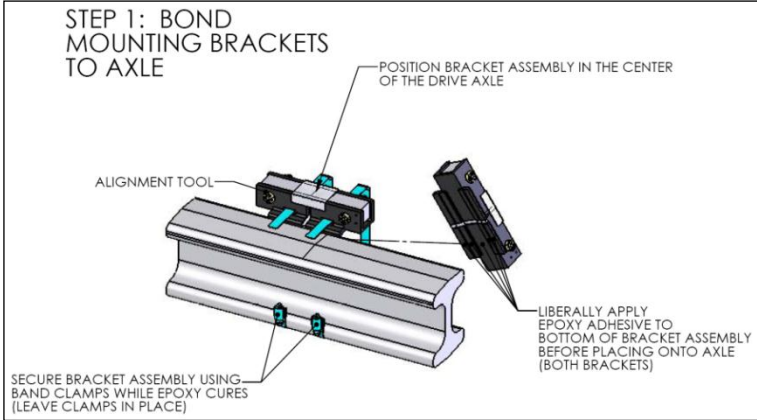

SENSOR INSTALLATION OVERVIEW DRAWINGS

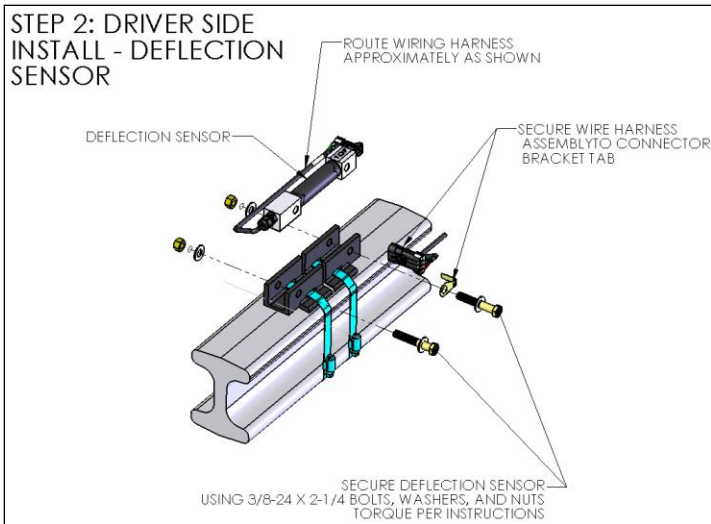

STEP 3: DRIVER SIDE INSTALL - COVER

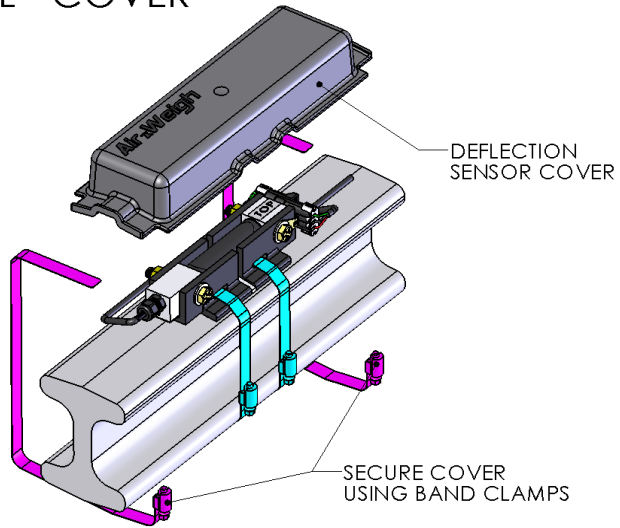

Alternate Step 2 and 3: Passenger Side Install - Cover.

ALTERNATE STEP 2: PASSENGER SIDE INSTALL - DEFLECTION SENSOR

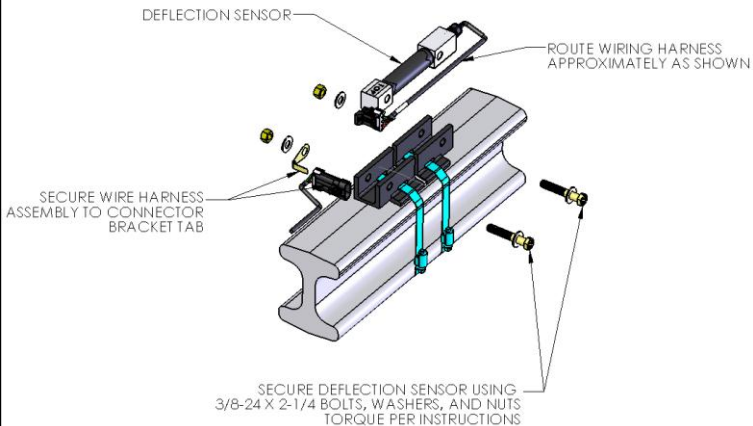

ALTERNATE STEP 3: PASSENGER SIDE INSTALL - COVER

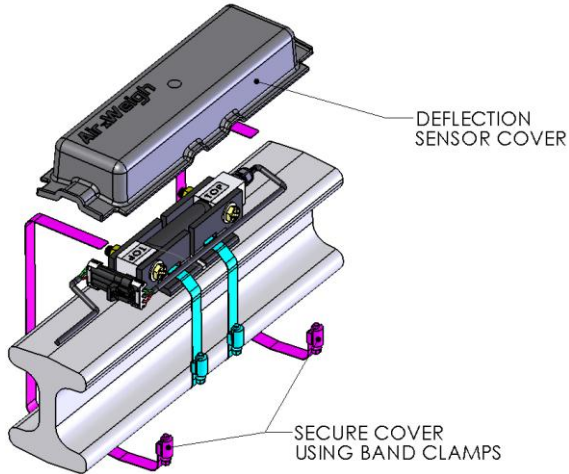

CAUTION

Do not move vehicle until the alignment tool is removed.



CAUTION

Do not calibrate sensor following installation until the vehicle has been in operation for one week or 800 miles, whichever comes first. This serves as a break-in period.

NOTE

Heavy calibration must be done using maximum vehicle loads. See document 901-0124-000 for additional information on calibration.

II. INSTALLATION COMPONENTS

The kits and parts for the QuickLoad installation described in this manual are shown in Table 1, below.

Table 1. Bill of Materials for Steer Axle Deflection Sensor Installation

PART NUMBER	DESCRIPTION	QTY
010-0097-00X	STEER AXLE BRACKET KIT, DEFLECTION SENSOR, BONDED	1
010-0021-001	ADHESIVE APPLICATION CONVERTER	1
110-0080-000	TAB, SS, CONN MOUNT, DEFLECTION SENSOR	1
111-0001-00X	BRACKET ASSEMBLY, DEFLECTION SENSOR, BONDED	1
120-0066-000	COVER ASSEMBLY, DEFLECTION SENSOR W/"CAUTION"	1
133-0009-000	WASHER, FLAT, 0.375 ID, PFC 9, THK,USS, STL, Y ZN PL	4
139-0016-000	CLAMP, BAND, 2 – 7 IN DIA, 23 IN LONG	4
145-0007-000	CABLE TIE, 0.30 X 24 IN, NYLON, BLK UV	6
145-4552-001	NYLON TIE, 7 in., T-50, NYLON, BLK	2
350-0035-000	PREPARATION PADS, ISOPROPYL ALCOHOL (SEE CAUTION)	6
350-0038-XXX	LOCTITE® H8700	1
350-0039-000	STATIC MIXER NOZZLE, 6 in	1
380-0004-001	SPLIT LOOM, 0.50 ft, 6 in	0.09
901-0145-000	INSTLL MANL, DEFL SNSR, STR AXLE	1
014-1500-028	DEFLECTION SENSOR CABLE	1
010-9093-XXX	DEFLECTION SENSOR	1

Bill Of Materials for Bracket Assembly 111-0001-00X

PART NUMBER	DESCRIPTION	QTY
110-0073-001	ALIGNMT TOOL,DEFL SNSR	1
114-0002-00x	MTG BRKT,DT,GLUED,7 DEG,2"W	2
131-0037-001	SCR-MACH,.375-24X2.25 HEX HD, STL, GR 8, Y ZN PL	2
132-0014-000	NUT-HEX, .375-24, GRD 8, Y ZN PL	2
350-0040-000	TAPE, VINYL, FOAM, 1/4", CLOSED CELL, FT	.22
350-0041-000	TAPE, FILAMENT, 2.36" – 3" WIDE, FT	.22
350-0053-000	FOAM, DIE-CUT, 1/8"	1

Note: Teromix-6700 may be used as an alternative to the glue PN 350-0038-xxx. See Appendix A for details.

WARNING

Isopropyl alcohol may cause mild irritation on contact with the skin as well as eye irritation. Immediately flush the affected areas with plenty of water, followed by washing with soap and water. Clothing contaminated with isopropyl alcohol should be removed immediately. Isopropyl alcohol should only be used in properly ventilated areas. Do not use in a confined space. Keep away from flames and other flammable materials.

CAUTION

Adhesive expires within one month (or three months if refrigerated) of scale ship date.

III. TOOLS REQUIRED (CUSTOMER SUPPLIED)

2. Required Tools

The list below contains the tools (customer supplied) to properly install the deflection sensors on the steer axle and on the Hendrickson Suspension.

- Sander/grinder
- 40-grit medium sandpaper
- Chalk or permanent marker
- Flat blade screwdriver
- 9/16-inch combination wrench
- Torque wrench, 20 – 80 ft-lb
- 9/16-inch socket and 3/8-inch socket handle
- Caulking gun
- Epoxy paint
- Tape measure

3. Optional

- 50 ml manual dispenser, Loctite™, P/N: 98472 LB 10985 (customer provided)
- Deflection Sensor Test Device, P/N: 1000

IV. *INSTALLING THE STEER AXLE SENSOR*



CAUTION

Do not move the vehicle until after removing the alignment tool.

1. Installing the Steer Axle Deflection Sensors

A. Preparing the Steer Axle and Sensor Brackets

1. Locate and mark the center of the steer axle. See Figure 1.

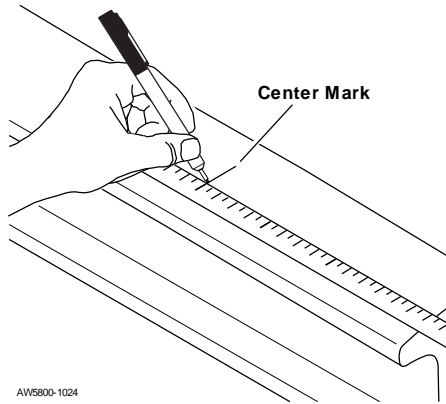

AW5800-1024

Figure 1. Marking the Center of the Steer Axle

2. Using a permanent marker, mark the top of the steer axle 3 in. on both sides of the center mark. The overall measurement is 6 in. Clean the entire marked-off area using two (2) of the supplied alcohol pads (P/N: 350-0035-000). See Figure 2.
3. Using 40-grit medium sandpaper, sand the marked off area until it is free of paint and other residues. See Figure 2.

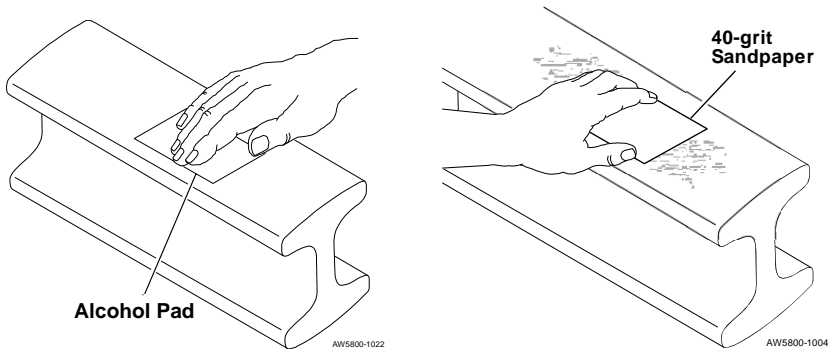

Figure 2. Cleaning and Sanding the Steer Axle



CAUTION

The steer axle must be cleaned *before* and *after* sanding the marked surface area and before installing the bracket with glue. Failure to clean the steer axle could result in the glue not adhering to the steer axle and the bracket.

4. Re-clean the sanded area on the steer axle using one of the supplied alcohol pads (P/N: 350-0035-000). See Figure 2.
5. Re-mark the center of the steer axle. See Figure 1.
6. Remove the protective coating strips from the bottom of the bracket assembly. See Figure 3.

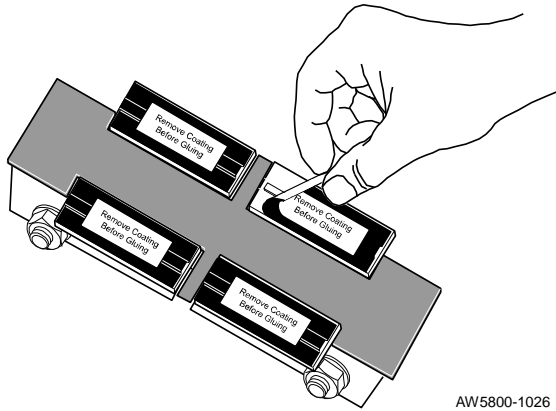

AW5800-1026

Figure 3. Removing the Protective Coating Strips

NOTE

Do not remove the protective foam pad on the bottom of the bracket attached to the bracket assembly.

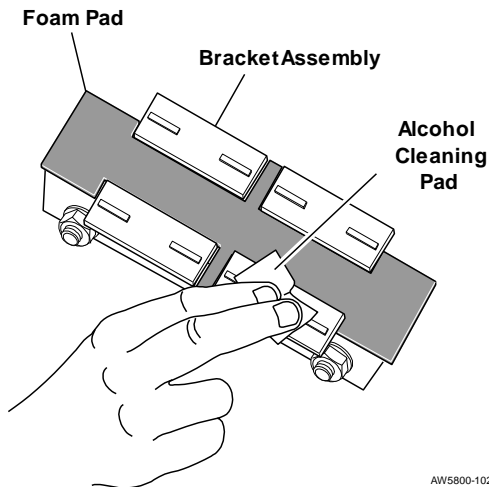

AW5800-1025

Figure 4. Cleaning the Bottom of the Bracket Assembly

7. Clean the underside of the bracket assembly (P/N: 111-0001-000) with one (1) of the supplied isopropyl alcohol pads (P/N: 350-0035-000). See Figure 4.

B. Assembling the Glue Kit

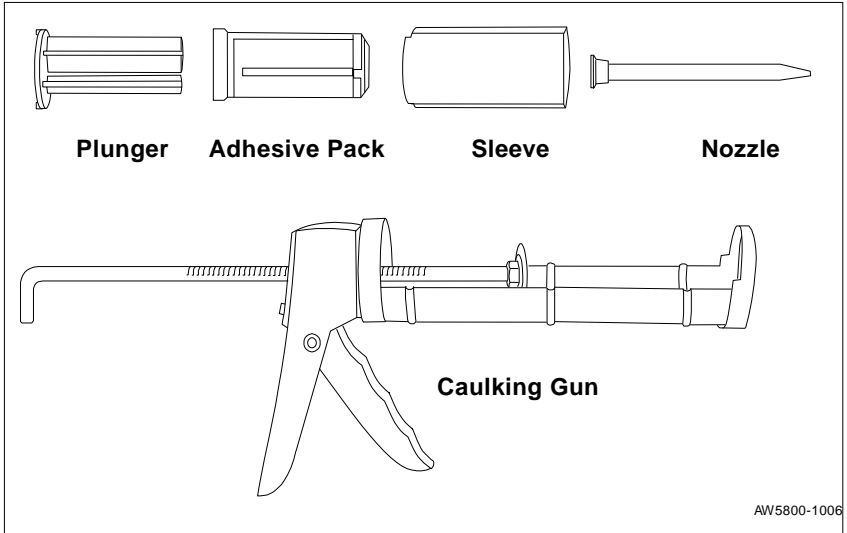

Figure 5. Glue Kit

Use the following steps to assemble the glue kit. See Figure 5.

1. Twist tab off glue cartridge.
2. Slide glue adhesive pack into sleeve. Align correctly because one side has a larger diameter.
3. Insert the blue plunger into the glue adhesive pack. Align correctly because one side has a larger diameter.
4. Insert nozzle into glue cartridge. Twist to secure. Insert glue cartridge into caulking gun.

5. Press trigger and dispense and discard a small amount of adhesive ensuring both sides of the duo-pak glue cartridge are flowing freely. See Figure 6. Trim end of nozzle to allow better flow, if necessary.

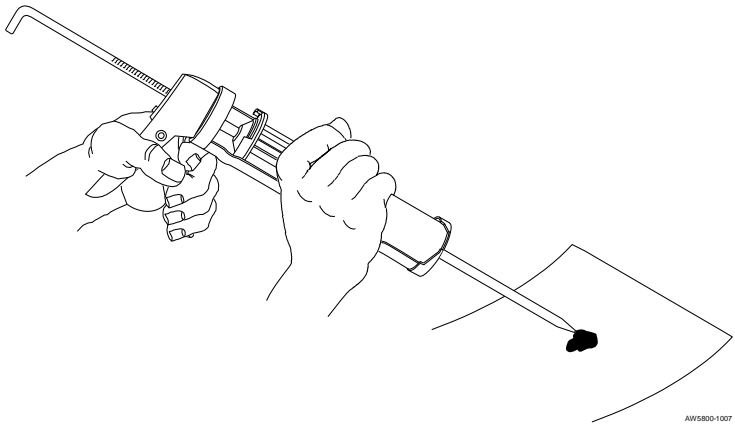

Figure 6. Clearing Duo-pak Adhesive

C. Applying the Adhesive

The working time for the glue at 73°F is approximately 10 minutes. Follow glue manufacturer's instructions.

1. Apply the adhesive **liberally** to the side wings on the bottom of the bracket assembly. See Figure 7.

NOTE

Do not remove the foam pad attached to the bottom of the sensor brackets.

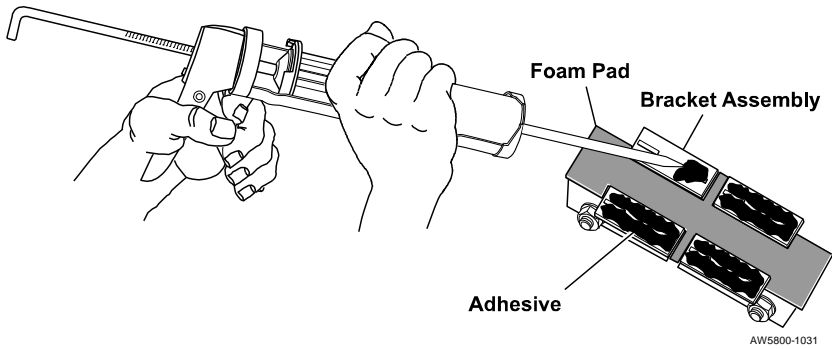

Figure 7. Applying Adhesive to the Bottom of the Bracket Assembly

D. Mounting the Brackets on the Steer Axle

1. Use the following steps to attach the mounting bracket to the steer axle.

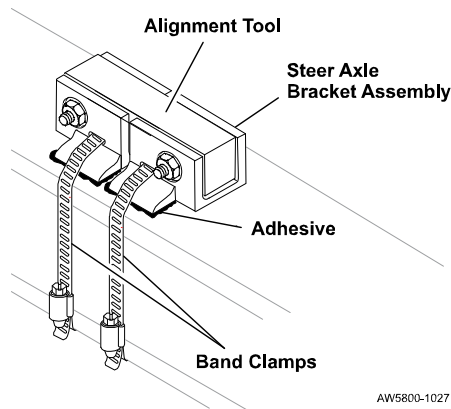

Figure 8. Placing Brackets on the Steer Axle

2. Place the mounting bracket assembly on the top center of steer axle.
3. Ensure the center of the bracket assembly aligns with the center mark previously made on the steer axle.

4. Place a band clamp (P/N: 139-0016-000) through the slot in the bottom of each bracket and wrap the band clamp around steer axle. See Figure 8.
5. Using a flat blade screwdriver, tighten the band clamps securely in place ensuring the mounting brackets remain parallel to the steer axle length.
6. Band clamps should be very tight. If necessary, to keep the bracket assembly parallel to the steer axle, loosen the band clamps and readjust the bracket assembly. Retighten the band clamps.
7. Allow time for the adhesive to cure. Refer to Table 2 for fixture and cure times. The deflection sensor may be installed after fixture time, per step IV.2, immediately below.

Table 2. Fixture and Cure Times for Adhesive

Ambient Temperature	Fixture Time	Cure Time
32° F (0° C)	12 Hours	24 Hours
54° F (12° C)	3 Hours	6 Hours
72° F (22° C)	2 Hours	4 Hours



CAUTION

Do not cure adhesive at temperatures exceeding 190°F (88°C).

After the adhesive has cured, apply Epoxy Paint to all the glue and axle seams and allow drying. The glue and axle seams must be painted with epoxy paint only after cure time.

Do not move the vehicle until the adhesive has cured and the alignment tool removed.

2. Deflection Sensor Installation

Proceed with the installation of the deflection sensor onto the steer axle after the adhesive has cured.

1. Remove the alignment tool from the brackets. It should fit loosely. Retain the two 3/8 bolts (P/N: 131-0037-001) and 3/8 nuts (P/N: 132-0014-000) for re-use during installation of the Deflection Sensor.
2. Clean the bracket channels with an alcohol pad.

A. Inserting the Sensor into the Bracket

1. Clean the sensor ends (P/N: 010-9093-XXX) with the remaining alcohol pad.
2. Insert the steer axle sensor with its cable extending towards the side of the vehicle where the sensor extension cable has been routed to the firewall. The "TOP" lettering on the sensor should face UP. See Figure 9.

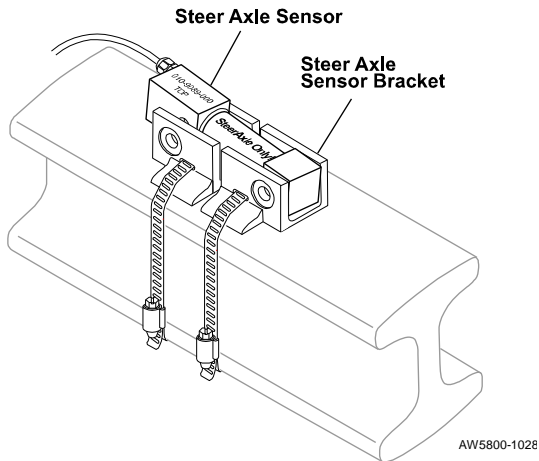

Figure 9. Inserting the Sensor into the Bracket

3. Align the steer axle sensor with the holes in the steer axle bracket assembly.

4. Insert one bolt and washer through the bracket hole on the sensor end with the word “TOP” on it. See Figure 10.

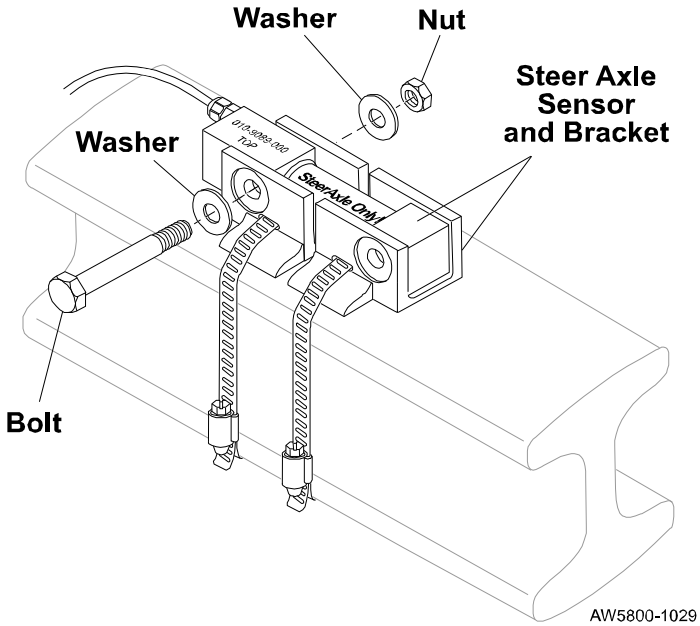

Figure 10. Assembling the Sensor and the Sensor Bracket

5. Insert the second bolt through the connector assembly bracket tab (P/N 110-0080-000), then through the 3/8-inch ID flat washer.
6. Slide the bolt through the bracket hole.
7. Ensure tongue and tab extends around the end of the sensor. See Figure 11. Place a hex nut (P/N: 132-0014-000) on each bolt and hand tighten.

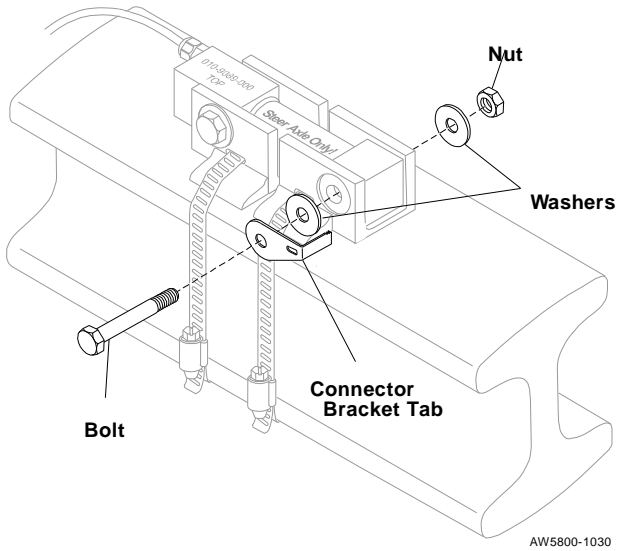

Figure 11. Installing the Connect Bracket

3. Setting the Sensor A/D Values

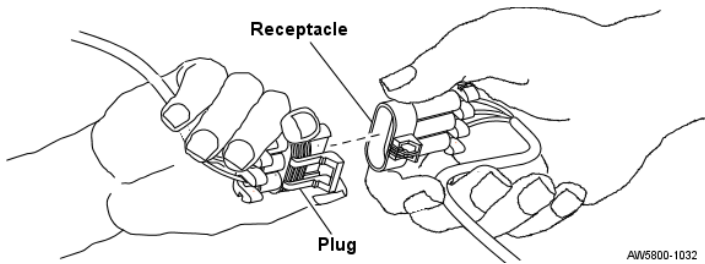

Figure 12. Assembling the Electrical Connector

A. Assembling the Connectors

Insert the Deflection Sensor connector plug into the Sensor Extension Cable connector,

- OR -

Connect to the P/N 1000 Deflection Sensor Test Device.

Ensure the locking tabs on the connector plug and connector receptacle engage completely. See Figure 12.



CAUTION

When tightening the sensor mounting bolts, ALWAYS use a torque wrench to check the torque on the nut, not the bolt head.

NOTE

The QuickLoad Scale must be installed, with deflection sensor connected and powered up – or use the Deflection Sensor Test Device – prior to checking the AD readings for these next steps. Refer to the Display Kit Installation Guide (P/N 901-0123-000) for installation instructions for the QuickLoad Scale.

Referencing “3. QuickLoad Connection Diagrams” in the Display Kit Installation Guide, ensure the Sensor Extension Cable is connected to the appropriate port on the QuickLoad Scale for your sensor configuration.

Then continue with the deflection sensor installation.

NOTE

A/D refers to the analog-to-digital conversion of the sensor reading.

B. Tightening the Nuts on the Sensor Assembly

1. Tighten the nut on the cable end of the sensor and use a torque wrench to torque to 25 ft-lbs. Torque will be increased in a later step.
2. Tighten the nut on the non-cable end of the sensor and use a torque wrench to torque to 25 ft-lbs. Torque will be increased in a later step.

Verify the A/D reading at this time using the display in the cab (the QuickLoad Scale must be connected to the Sensor, and

powered up) or using the Deflection Sensor Test Device. If within range (750 – 1250), proceed to Step E.1. Otherwise, proceed as below:

C. A/D Reading is BELOW 750

If the A/D reading is **below 750** or there is no A/D reading at all, follow these steps to exert a pre-load on the sensor.

1. Loosen the nut on **the non-cable end** of the sensor.
2. Exert upward pressure lightly with your fingers (or a screwdriver, if necessary) under **the non-cable end** of the sensor until an appropriate A/D reading is reached, for example:

750 TO 1250

3. Tighten the nut on **the non-cable end** of sensor and torque to 25 ft-lbs. If the A/D readings are still within proper range, proceed to Step E.1.

D. A/D Reading is ABOVE 1250

If the A/D reading is **above 1250**, follow these steps to exert a pre-load on the sensor.

1. Loosen the nut on **the non-cable end** of the sensor.
2. Exert downward pressure lightly with your fingers on **the non-cable end** of the sensor until an appropriate A/D reading is reached. Tighten nut and torque to 25 ft-lbs.
3. Check A/D reading; if they are below 750 repeat Step C: 1 – 3 (above). If they are above 1250, repeat Step D: 1 – 3. If within range proceed to Step E.1.

E. Final Sensor Torque

1. Tighten the nut on the cable end of the sensor and torque to 50 ft-lbs.

2. Tighten the nut on the non-cable end of the sensor and torque to 50 ft-lbs.

Perform a final check of A/D values. If not within range, repeat Steps C or D.

If using the Deflection Sensor Test Device, disconnect the test fixture and connect deflection sensor cable to sensor extension cable to form a connector assembly. Proceed with next step of installation.

F. Attaching Connector Assembly to Bracket Tab

1. Slide the connector assembly onto the connector bracket tab mounted on the deflection sensor bracket, by inserting the tab into the grooves on the bottom side of the connector receptacle. See Figure 11. Ensure the connector assembly slides completely on the mounting tab.
2. Route the cable coming out of the receptacle portion of the connector assembly so it can be used for a driver's side hookup or a passenger side hookup. See Step G for a driver's side hookup and Step H for a passenger's side hookup.

NOTE

Ensure there is enough slack in the Sensor Extension cable between the axle and the frame to allow for axle movement.

G. Driver's Side Sensor Orientation

1. Facing towards the rear of the vehicle, route the cable from the connector assembly so it runs to the right of the steer axle sensor assembly. See Figure 13.

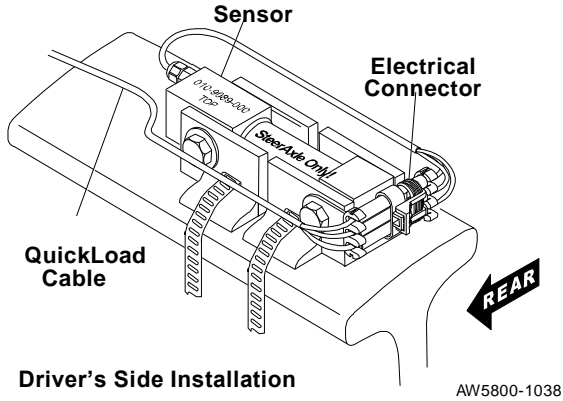

Figure 13. Placing the QuickLoad Scale Cable for a Driver's Side Hookup

H. Passenger Side Sensor Orientation

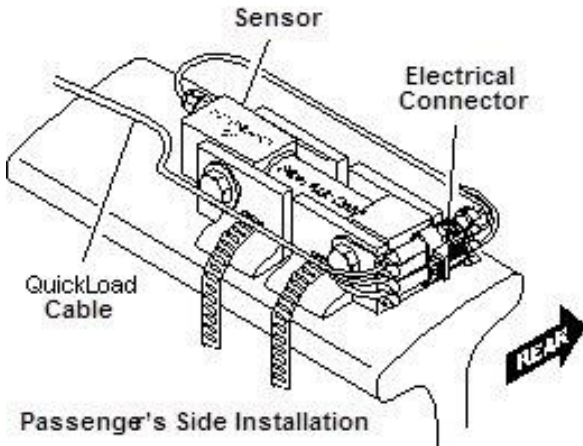

Figure 14. Placing the QuickLoad Scale Cable for Passenger's Side Hookup

1. Facing towards the rear of the vehicle, route the cable from the connector assembly so it runs to the left of the steer axle sensor assembly. See Figure 14.

I. Installing the Cover

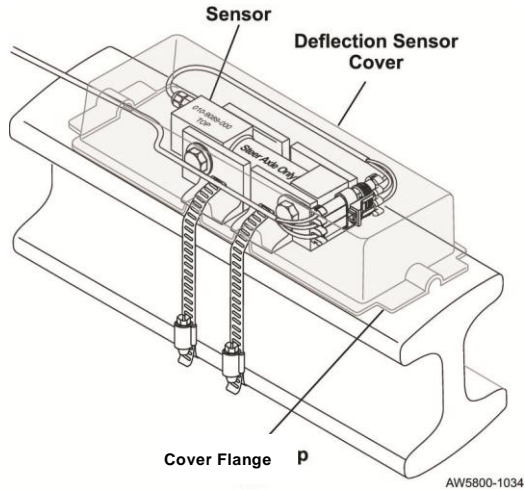

Figure 15. Placing the Cover Over the Deflection Sensor Assembly

1. Mount the cover on top of the sensor and sensor brackets so that the sensor cable is completely under the cover. The bracket band clamps should emerge from the cover's side ports. See Figure 15.
2. The sensor extension cable should emerge from the cover's end port on the side that you will be routing the cable to the firewall.
3. Very loosely install band clamps (P/N: 139-0016-000) around the steer axle on both ends of the deflection sensor cover. Ensure that the band clamp on each side circles both the steer axle and the cover flange. See Figure 16.
4. Installation of the Steer Deflection Sensor is complete. Figure 17 shows covered sensor with sensor cable extending towards the QuickLoad Scale module.

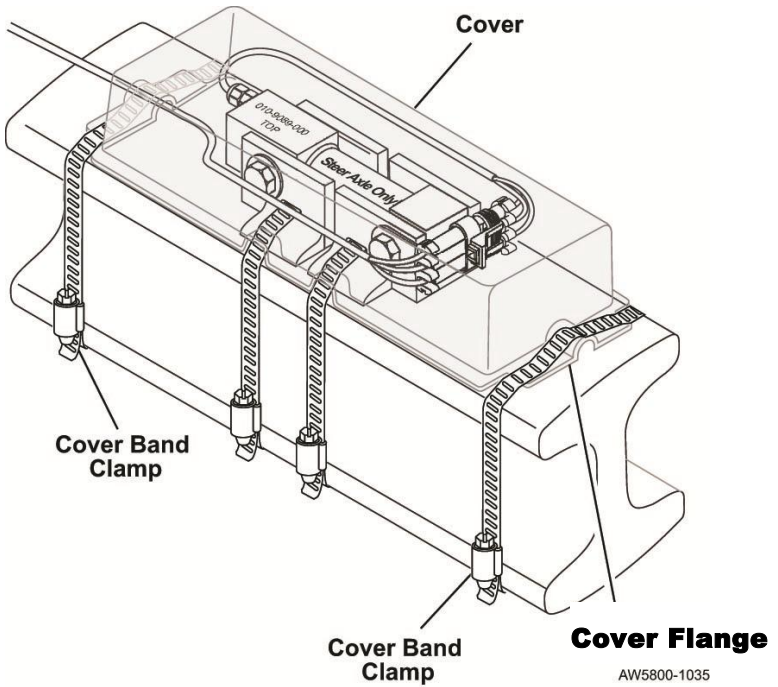

Figure 16. Attaching Band Clamps to Cover

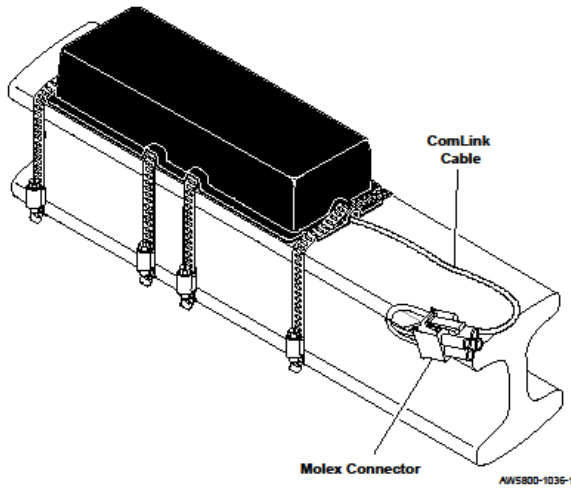

Figure 17. Cover with Sensor Extension Cable

5. Routing the sensor cable: Run the drive sensor extension cable along the rear of the axle towards the side of the truck (driver's side or passenger's side), securing with a band clamp (P/N: 139-0016-000). Place split loom (P/N: 380-0004-001) over the band clamp where it crosses over the cable. Secure the cable to the band clamp with nylon ties (P/N: 145-4552-001). See Figure 18. Use additional 24" nylon ties (P/N: 145-0007-000) as required to secure the cable to the steer axle.

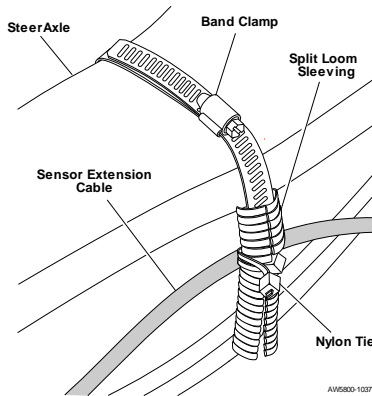

Figure 18. Securing the Sensor Extension Cable



CAUTION

Following sensor installation, do not calibrate until after the vehicle has been in normal operation for a week or 800 miles, whichever comes first. This allows for a break-in period for the sensor.

Do not operate the vehicle with the alignment tool in place.

NOTE

Heavy calibration must be done using maximum vehicle loads. See document 901-0124-000 for additional information on calibration.

Your Air-Weigh steer axle sensor installation is now complete.

Limited Warranty

For product failures due to material or manufacturing defects, Air-Weigh will replace or repair all components for up to 3 years from shipment date to the end-user Air-Weigh customer. These three-year components include: Displays, ComLinks, Sensors, Power Cables, Sensor Assemblies, Sensor Harnesses, and all other associated external components. Air-Weigh assumes no responsibility for administering warranty claims directly with any third party end users.

The responsibility of Air-Weigh under this warranty is limited to the repair, replacement, or credit of the defective part or assembly.

This warranty does not cover incidental or consequential damage to persons or property caused by use, abuse, misuse, or failure to comply with installation or operating instructions. This limited warranty does not apply to any product that has failed due to accident, abuse, alteration, installation not consistent with printed installation instructions, improper maintenance, improper operation, or as a result of system integration or installation not explicitly approved in writing by Air-Weigh.

Air-Weigh and its resellers shall have no responsibility or liability for damages if the purchaser or any other person alters the vehicle incorporating Air-Weigh products. This limited warranty shall not apply to any product that has been repaired or altered by anyone not employed by Air-Weigh or not operated in accordance with the manufacturer's printed material delivered with this product.

Air-Weigh hereby expressly disclaims any and all implied warranties of any type, kind of nature whatsoever, and particularly any implied warranty of merchantability or fitness for a particular purpose not expressly stated by Air-Weigh in its printed material delivered with its products.

Some states do not allow the exclusion or limitation of incidental or consequential damages. If such laws apply, the limitations or exclusions contained in the terms and conditions of this Warranty may not apply. This warranty gives you specific legal rights and you may also have other rights, which vary state to state.

May be covered by U.S. Patent Nos. 5478974, 5780782, 7478001

Foreign Patent Nos. 260494, 677998, 2122766

Copyright © 2004, 2006, 2007, 2010, 2011 by Hi-Tech Transport Electronics, Inc. All rights reserved. Air-Weigh®, ComLink™, and Hi-Tech Transport Electronics are trademarks or registered trademarks of Hi-Tech Transport Electronics, Incorporated. Other brand, product, or service names listed in this document are the trademarks or registered trademarks of their respective holders. Information contained in this literature was accurate at time of publication. Product changes may have been made after copyright dates that are not reflected in this document.

Procedure for Warranty Claims

1. For a warranty claim of an Air-Weigh product, customers should get the part number, serial number, and failure description of the failed item and call Air-Weigh Customer Support. Air-Weigh will replace or repair units that have failed due to workmanship, at the discretion of Air-Weigh. In the event that Air-Weigh requests to examine product prior to disposition, or for repairs or replacements, Air-Weigh requires a Return Material Authorization (RMA) number to be issued before the item is returned. Customers should contact Air-Weigh's Customer Support Department at (888) 459-3247 for an RMA number. Please reference this RMA number in all correspondence.
2. Claimed items shall be shipped freight pre-paid to: Air-Weigh, Customer Support Department, 1730 Willow Creek Circle, Eugene, Oregon 97402, USA. The Air-Weigh RMA number shall appear on the outside of the return packaging.
3. Air-Weigh shall examine returned material within 30 days after receipt, or sooner if mutually agreed upon. If Air-Weigh determines that the part or assembly was defective in material or workmanship and within the warranty period, Air-Weigh will repair or replace the part or assembly and return freight pre-paid. In the event Air-Weigh determines that the part or assembly cannot be repaired or replaced and is within the warranty period, a credit not to exceed the purchase price will be issued to the Air-Weigh customer.
4. Air-Weigh Accounting will process a credit memo and notify the Air-Weigh customer by email or fax. The Air-Weigh customer will process a corresponding debit memo and notify Air-Weigh Accounting.
5. If the part or assembly received by Air-Weigh does not meet the requirements of the warranty program set forth above, at the Air-Weigh customer's request the part or assembly will either be discarded, returned freight collect, or repaired or replaced at the Air-Weigh customer's expense and returned freight collect.

APPENDIX A

TEROMIX-6700

Product Description

Teromix-6700 is a polyurethane-based two-component adhesive that cures at room temperature. Curing can be accelerated by increasing the temperature (e.g. IR radiator). The product is supplied in a convenient twin cartridge and is rapid-curing. Teromix-6700 can be painted with normal commercial car paints. Follow manufacturer's instructions for application.

Application Areas

Teromix-6700 is used in motor vehicle body repair shops for bonding customizing and body parts.

Examples of possible applications include:

- antiflutter/stiffening (motor hood with strut, roof skin and framing), wing and wheel housing
- bonding of plastic components such as glass fibre reinforced duromers (SMC, BMC/ZMC) to each other and to metals
- corrosion protection on hem flange joints.

Technical Data

Component A, Component B

Color: beige, black

Density: approx. 1.4 g/cm³ approx. 1.7 g/cm³

Solids (3 h at 100°C): > 98 % > 98 %

Mixing ratio by volume: 100 : 100

Mixture (components A + B)

Color: dark grey

Pot life (100 g, 23°C): approx. 10 mins

Tack-free time: approx. 30 mins

Solid to hand pressure: at 23°C approx. 2 hrs

at 80°C approx. 10 mins

Curing time at 23°C: approx. 6 hours (85 % of final strength)

Shore A hardness: approx. 90

Shear Strength: approx. 23 MPa on

(measured after 2 d at 23°C): approx. 13 MPa

Cross head speed: 100 mm/minute

Paintability: good

In service temperature range: -40°C to 80°C

Short exposure (up to 1 hour): 140°C

Pretreatment of the adhesion surfaces

The parts to be joined must be free from oil, grease, moisture, dirt and release agents.

One proven method of preparing the bonding faces of plastics is mechanical roughening of the surface (brushing, abrasive rubbing, sandblasting). Such mechanical treatment removes adhesion-inhibiting surface layers (e.g. release agents). Metals may either be primed (e.g. cathodic EC, 2-component epoxy resin primer) or they should be grinded.

The Teromix system

The Teromix system consists of the Teromix hand gun, the efficient Teromix-6700 double cartridge and a mixer nozzle (static mixer). Precise instructions are included with every pack.

Inserting the cartridge

Push the lock on the Teromix hand gun upwards and draw the piston bar back as far as the stop. Place the Teromix cartridge in the cartridge guide, unscrew the cap from the cartridge and screw on the mixer nozzle. Cut the end of the mixer nozzle to produce the desired size of bead.

Applying Teromix-6700

When the gun lever is operated, the material is forced through the mixer nozzle and the two components are automatically mixed.

(Do not use the first 2 cm of extruded adhesive bead, for these might not be perfectly mixed.) Teromix-6700 is applied directly onto the substrate without the need for any chemical primer. Any excess material should be removed immediately after application.

The cured adhesive within the mixer will seal the cartridge. A new mixer nozzle will have to be used if the cartridge is re-used.

Curing

The bonded joint can be worked mechanically after 2 hours at room temperature; a waiting period of 15 minutes is sufficient if an infra-red radiator is used with a temperature of 60°C. The infra-red radiator should be placed at a distance of ca. 30 cm from the bond. Object temperature 60°C.

Cleaning

Fresh, non-cured material (e. g. for cleaning tools, cleaning contaminations on the substrates etc.) may first be removed dry and then cleaned off with a suitable solvent (e.g. acetone, ethyl acetate, Cleaner-A, Cleaner-D). Cured adhesive can only be removed mechanically.



1730 Willow Creek Circle • Eugene, Oregon 97402-9152 USA
P.O. Box 24308 • Eugene, Oregon 97402-0437 USA

Telephone (541) 343-7884 • Order Desk (888) 459-3444
Customer Support (888) 459-3247 • FAX (541) 431-3121
Hours of Operation: Mon-Fri, 8am – 5pm, Pacific Time
www.Air-Weigh.com